

Wavelet Based Adaptive Fast Solution of Boundary Integral Equations

Wolfgang Dahmen, Helmut Harbrecht* and Reinhold Schneider*

* Fakultät für Mathematik
Technische Universität Chemnitz

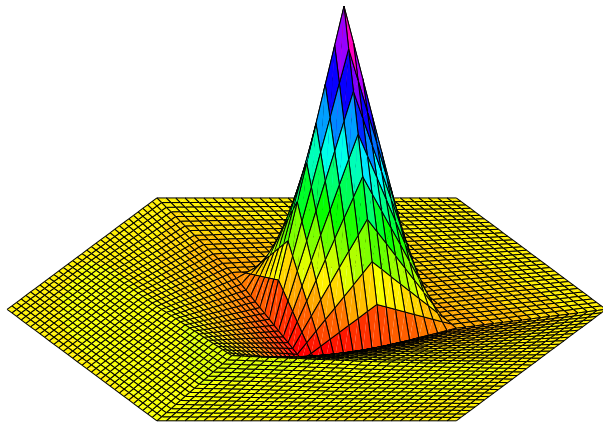

Operator Equation

E.g. *Boundary Integral Equations*

(Exterior) boundary value problem of second order:

e.g. Laplace, Stokes, Maxwell equation etc.

$$\mathcal{A}u = f \quad \text{on} \quad \Gamma = \partial\Omega \subset \mathbb{R}^3$$

$$\mathcal{A} : H^t(\Gamma) \rightarrow H^{-t}(\Gamma), \quad (\mathcal{A}u)(\mathbf{x}) = \int_{\Gamma} k(\mathbf{x}, \mathbf{y})u(\mathbf{y})d\sigma_{\mathbf{y}}$$



Decay property of the kernels of boundary integral operators

$$|\partial_{\mathbf{x}}^{\alpha} \partial_{\mathbf{y}}^{\beta} k(\mathbf{x}, \mathbf{y})| \lesssim \|\mathbf{x} - \mathbf{y}\|^{-(2+2t+|\alpha|+|\beta|)}$$

Examples for the Laplacian:

□ single layer operator: $\mathcal{A} = \mathcal{V}$, $t = -\frac{1}{2}$, f Dirichlet data

$$(\mathcal{V}u)(\mathbf{x}) = \frac{1}{4\pi} \int_{\Gamma} \frac{1}{\|\mathbf{x} - \mathbf{y}\|} u(\mathbf{y}) d\sigma_{\mathbf{y}}$$

□ double layer operator: $\mathcal{A} = \mathcal{K} \pm \frac{1}{2}$, $t = 0$, f Dirichlet data

$$(\mathcal{K}u)(\mathbf{x}) = \frac{1}{4\pi} \int_{\Gamma} \frac{\langle \mathbf{x} - \mathbf{y}, \mathbf{n}_{\mathbf{y}} \rangle}{\|\mathbf{x} - \mathbf{y}\|^3} u(\mathbf{y}) d\sigma_{\mathbf{y}}$$

□ hypersingular operator: $\mathcal{A} = \mathcal{W}$, $t = \frac{1}{2}$, f Neumann data

$$(\mathcal{W}u)(\mathbf{x}) = -\frac{1}{4\pi} \frac{\partial}{\partial \mathbf{n}_{\mathbf{x}}} \int_{\Gamma} \frac{\langle \mathbf{x} - \mathbf{y}, \mathbf{n}_{\mathbf{y}} \rangle}{\|\mathbf{x} - \mathbf{y}\|^3} u(\mathbf{y}) d\sigma_{\mathbf{y}}$$

Best N-Term Approximation:

Give u , assume $u_\Lambda = \sum_{\lambda \in \mathcal{I}} u_\lambda \psi_\lambda$ with $\#\mathcal{I} = N$

$$\inf_{\#\mathcal{I}=N} \|u - u_\Lambda\| \lesssim N^{-s}$$



Ultimate Goal :

Compute an approximate solution u_{approx} of $Au = f$, s.t

$$\|u - u_{approx}\| \lesssim N^{-s} \quad \text{within Complexity } \sim N$$

Fast Methods for Integral operators

Adaptive kernel approximation:

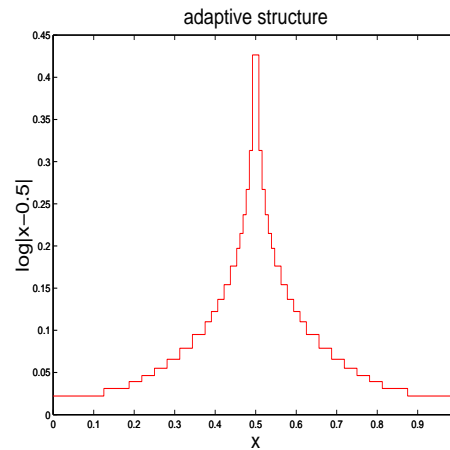
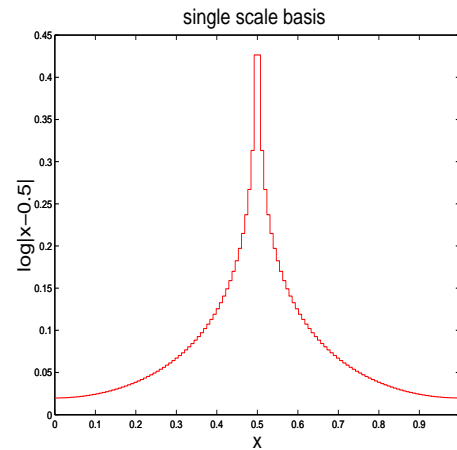

- Fast Multipole Method (Greengard, Rokhlin, . . .)
- Panel Clustering and H-matrices (Hackbusch-Nowak, . . .)
- Wavelet Galerkin Scheme
(Beylkin-Coifman-Rokhlin, Dahmen-Pröbldorf-Schneider, . . .)

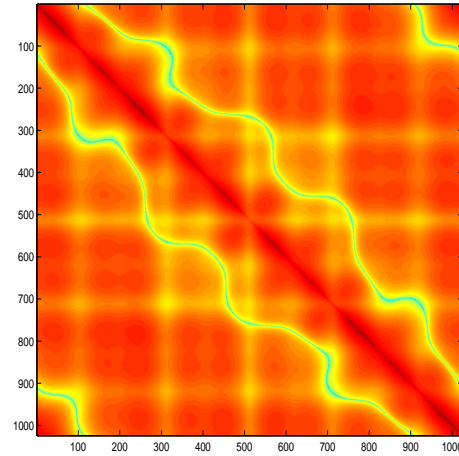

single-scale basis

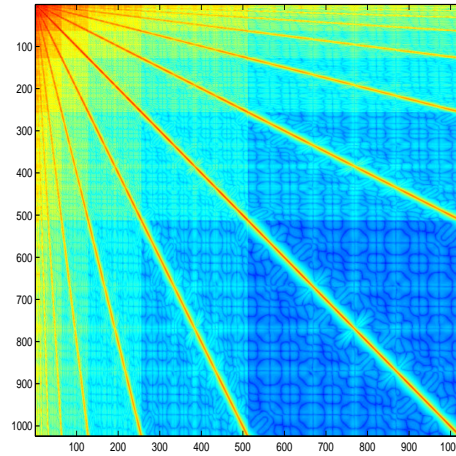

wavelet basis

⇒ Linear system:

$$\mathbf{A}_\psi \mathbf{u}_\psi = \mathbf{f}_\psi$$

Biorthogonal Wavelet Bases

Multiscale hierarchy: $V_j = \text{span}\{\phi_{j,k} : k \in \Delta_j\}$

$$(V_{-l} \subset V_{-l+1} \subset \dots) V_0 \subset V_1 \subset \dots \subset V_j \subset V_{j+1} \subset \dots \subset L^2(\Gamma)$$

← (Coarsening, *Tausch*, *White*) Refinement →



Multiscale decomposition and wavelets:

□ Decomposition:

$$V_{j+1} = V_j \oplus W_j, \quad V_J = \bigoplus_{j=-1}^{J-1} W_j, \quad W_{-1} := V_0$$

□ Wavelets:

$$W_j = \text{span}\{\psi_{j,k} : k \in \nabla_j := \Delta_{j+1} \setminus \Delta_j\}$$

□ Compact supports:

$$\text{diam supp } \psi_{j,k} \sim 2^{-j}$$

□ Normalization:

$$\|\psi_{j,k}\|_{L^2(\Gamma)} \sim 1$$

□ Biorthogonality: $\langle \psi_{j,k}, \tilde{\psi}_{j',k'} \rangle = \delta_{(j,k),(j',k')}$

$$\tilde{V}_0 \subset \tilde{V}_1 \subset \dots \subset \tilde{V}_j \subset \tilde{V}_{j+1} \subset \dots \subset L^2(\Gamma)$$

□ Regularity and Stability:

$$\gamma := \sup\{s \in \mathbb{R} : \psi_{j,k} \in H^s(\Gamma)\} > +t$$



$$\tilde{\gamma} := \sup\{s \in \mathbb{R} : \tilde{\psi}_{j,k} \in H^s(\Gamma)\} > -t$$

□ Cancellation Property: (\tilde{d} vanishing moments)

$$|\langle \psi_{j,k}, f \rangle| \lesssim 2^{-j(\tilde{d}+1)} |f|_{W^{\tilde{d},\infty}(\text{supp } \psi_{j,k})}$$

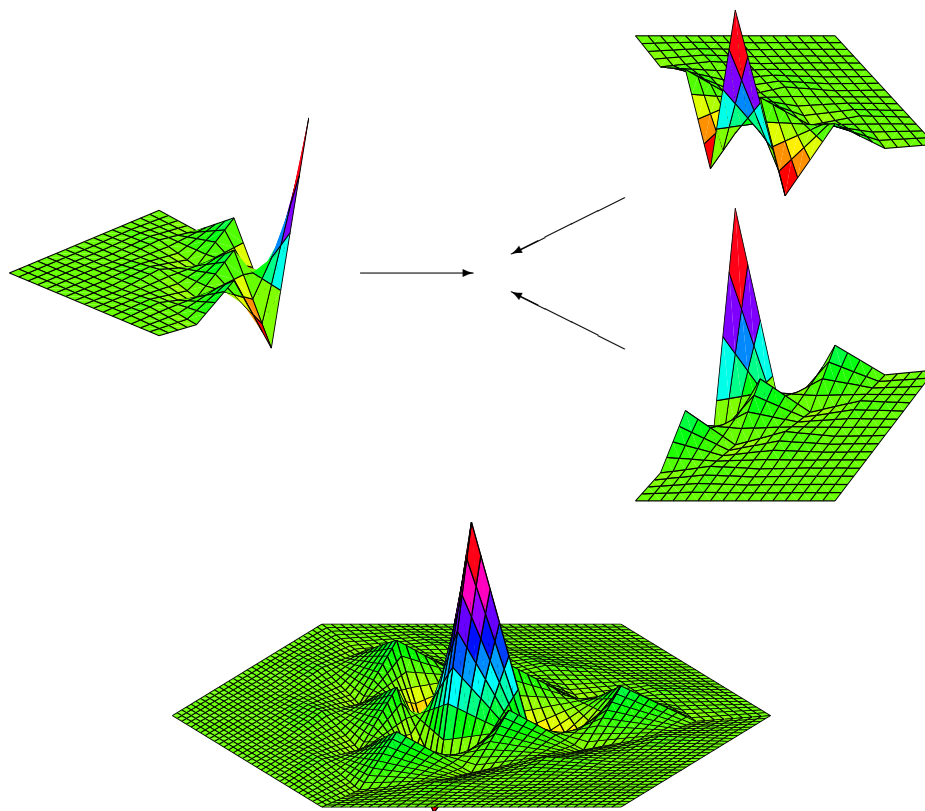
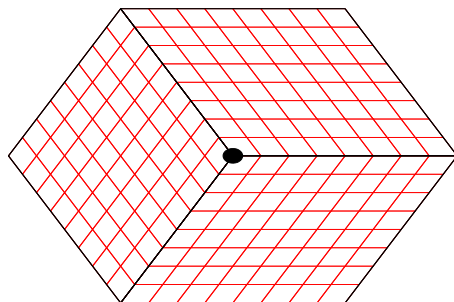

Preconditioning

Theorem (Norm equivalences):

1. Sobolev spaces

$$\|u\|_s^2 \sim \sum_{\lambda} |(u, \tilde{\psi}_{\lambda})_{\Gamma}|^2 2^{2|\lambda|s}$$



2. Besov spaces

$$\|u\|_{B_{p,p}^s}^p \sim \sum_{\lambda} |\langle u, \tilde{\psi}_{\lambda} \rangle|^p, \quad s = n\left(\frac{1}{p} - \frac{1}{2}\right)$$



□ Diagonal scaling: (Dahmen-Kunoth, Schneider)

The condition number of the diagonally scaled system matrix

is uniformly bounded if $\tilde{\gamma} > -t$.

Adaptive wavelet scheme

Normalisation $\|\psi_\lambda\|_t \sim 1 \rightarrow$ norm equivalence

$$\|u\| \sim \|\mathbf{u}\|_{l_2}$$

Best N-Term Approximation:

Rearranging \mathbf{u} by $\mathbf{u}^* = (u_k^*)_{k \in \mathbb{N}}$, i.e. $|u_k^*| \leq |u_{k-1}^*|$, provides a quasi-norm for weak l^τ -spaces

$$\|\mathbf{u}\|_{l_\tau^w(\mathcal{J})} := \sup_{k>0} (k^{1/\tau} |u_k^*|).$$

$$\|u - u_\Lambda\|^2 \sim \sum_{\lambda \notin \mathcal{I}} |u_\lambda|^2 \lesssim N^{-s} \|\mathbf{u}\|_{l_\tau^w(\mathcal{J})}^2, \quad \frac{1}{\tau} = \frac{1}{2} + s$$

Tree approximation

The local residuals are given by

$$\tilde{u}_\lambda^2 := |u_\lambda|^2 + \sum_{\mu \prec \lambda} |u_\mu|^2$$

For $\eta > 0$

$$\mathcal{T}_\eta = \mathcal{T}_\eta(\mathbf{u}) := \{\lambda \in \mathcal{J} : |\tilde{u}_\lambda| > \eta\}$$

is a tree.

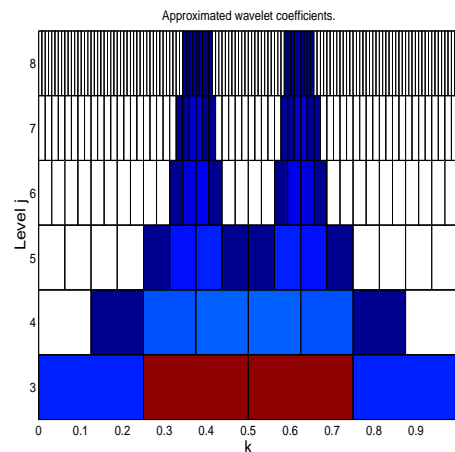

structure of adaptive wavelet tree approximation

■ We introduce the *tree weak spaces*

$${}_t l_\tau^w = {}_t l_\tau^w(\mathcal{J}) = \{\mathbf{u} \in l_2(\mathcal{J}) : (\tilde{u}_\lambda)_{\lambda \in \mathcal{J}} =: \tilde{\mathbf{u}} \in l_\tau^w\}$$

Tree layers

The tree $\mathcal{T}(\epsilon, \mathbf{u})$ satisfies

$$\|\mathbf{u} - \mathbf{u}|_{\mathcal{T}(\epsilon, \mathbf{u})}\| \leq \epsilon.$$

We define

$$\mathcal{T}_j := \mathcal{T}\left(\epsilon \frac{2^{js}}{j+1}, \mathbf{u}\right).$$

and *tree layers*

$$\Delta_j := \mathcal{T}_j \setminus \mathcal{T}_{j+1}, \quad j = 0, \dots, J = J(\epsilon).$$

These layers play a similar role as the levels $\mathbf{u}_j := \mathbf{u}|_{\Delta_j}$, $\mathbf{u}_\epsilon = \sum_{l=0}^J \mathbf{u}_l$, ■

Compressible matrices

Let $u = \sum_{\lambda} u_{\lambda} \psi_{\lambda} \in H^t$ and $\mathbf{A}_{\lambda, \lambda'} = (\mathcal{A}\psi_{\lambda}, \psi_{\lambda'})_{\Gamma}$

$\mathcal{A} : H^t \rightarrow (H^t)'$ corresponds to $\mathbf{A} : l_2 \rightarrow l_2$

Compressed matrices

$$\mathbf{A}_j : l^2(\mathcal{J}) \rightarrow l^2(\mathcal{J}), \quad \text{nnz}_{\text{row}} \mathbf{A}_j \lesssim \frac{2^j}{(j+1)^\alpha}$$

and

$$\|\mathbf{A} - \mathbf{A}_j\| \lesssim \frac{2^{-js}}{j+1}.$$

Suppose $\mathbf{u} \in \mathcal{L}_\tau^w$ and \mathbf{u}_ϵ is the best tree N -term approximation of \mathbf{u} satisfying $\|\mathbf{u} - \mathbf{u}_\epsilon\| \leq \epsilon$. We approximate $\mathbf{A}\mathbf{u}_\epsilon$ by \mathbf{w}_J ,

$$\mathbf{w}_J := \sum_{j=0}^J \mathbf{A}_j \mathbf{u}_j,$$

then the computational cost is $\lesssim \epsilon^{-1/s} = N = N(\epsilon)$ and the accuracy is

$$\|\mathbf{A}\mathbf{u} - \mathbf{w}_J\| \lesssim \epsilon.$$

Prediction set: $\mathcal{T}_{new} := \text{supp}\mathbf{w}_J$ is a tree $\#\mathcal{T}_0 \sim \#\mathcal{T}_{new}$.

Iterative scheme:

$$\mathbf{u}^{n+1} = \mathbf{u}^n - \omega \mathbf{C}^{-1} \mathbf{A}(\mathbf{u}^n - \mathbf{f}^n)$$

A-priori Matrix Compression

Estimate:
$$|(\mathcal{A}\psi_{j,k}, \psi_{j',k'})_{L^2(\Gamma)}| \leq c \frac{2^{(j+j')(\tilde{d}+n/2)}}{\text{dist}(\text{supp } \psi_{j,k}, \text{supp } \psi_{j',k'})^{n+2t+2\tilde{d}}}$$

1. Compression:
 (Dahmen-Pröbldorf-
 Schneider,
 von Petersdorff-Schwab)

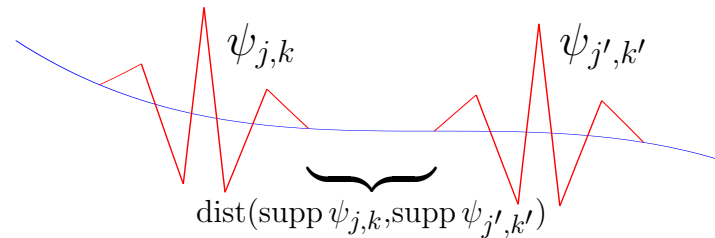

$$(\mathcal{A}\psi_{j,k}, \psi_{j',k'})_{L^2(\Gamma)} := 0$$

if $\text{dist}(\text{supp } \psi_{j,k}, \text{supp } \psi_{j',k'}) > \mathcal{B}_{j,j'}$

where
$$\mathcal{B}_{j,j'} = a \max \left\{ 2^{-\min\{j,j'\}}, 2^{\frac{2J(\delta-t)-(j+j')(\delta+\tilde{d})}{2(\tilde{d}+t)}} \right\}$$

2. Compression:
(Schneider)

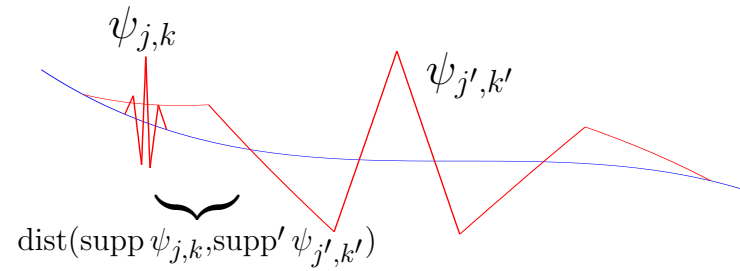

$$(\mathcal{A}\psi_{j,k}, \psi_{j',k'})_{L^2(\Gamma)} := 0$$

$$\text{if } \text{dist}(\text{supp } \psi_{j,k}, \text{supp}' \psi_{j',k'}) > \mathcal{B}'_{j,j'}$$

$$\text{where } \mathcal{B}'_{j,j'} = a' \max \left\{ 2^{-\max\{j,j'\}}, 2^{\frac{2J(\delta'-t)-(j+j')\delta'-\max\{j,j'\}\tilde{d}}{\tilde{d}+2t}} \right\}$$

$\rightsquigarrow \mathcal{O}(N_J)$ relevant matrix coefficients

$$(a, a' > 1, d < \delta, \delta' < \tilde{d} + 2t)$$

Error Analysis:

Theorem : The solution of the compressed wavelet scheme converges with optimal order

$$\|u - u_J^\epsilon\|_{2t-d} \lesssim 2^{-2J(d-t)} \|u\|_d$$

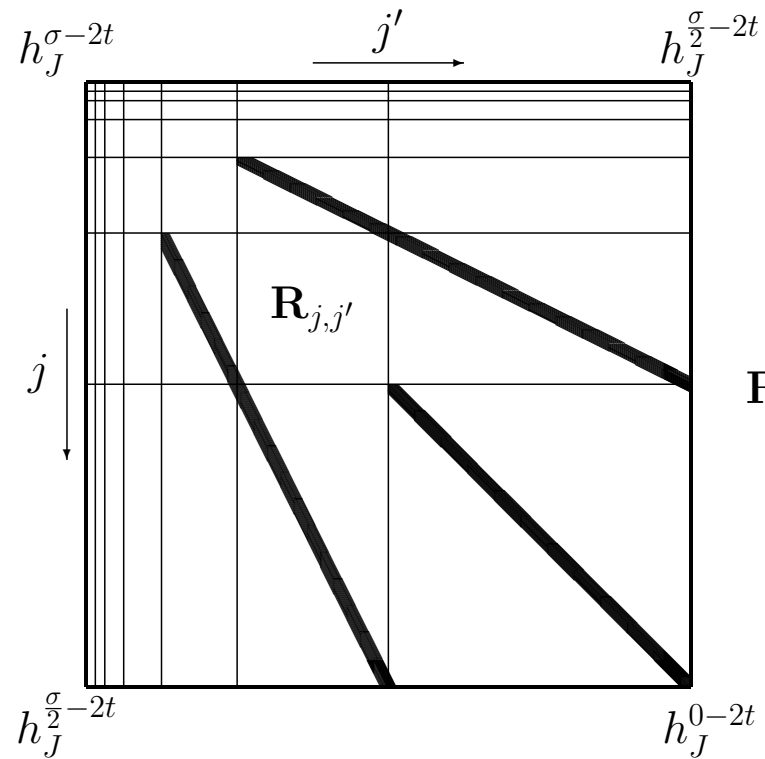

$$\mathbf{R}_{j,j'} := \mathbf{A}_{j,j'}^\psi - \tilde{\mathbf{A}}_{j,j'}^\psi$$

$$h_J := 2^{-J}$$

$$\sigma := 2d', \quad d' > d$$

Complexity:

Theorem : If the computation of a relevant matrix coefficient $(\mathcal{A}\psi_{j,k}, \psi_{j',k'})_{L^2(\Gamma)}$ requires

$$\mathcal{O}\left(\left[J - \frac{j+j'}{2}\right]^\alpha\right), \quad \alpha \geq 0,$$

operations, the complexity of assembling the compressed system matrix scales linearly.



A-posteriori matrix compression:

Define $(\mathcal{A}\psi_{j,k}, \psi_{j',k'})_{L^2(\Gamma)} := 0$

if $|(\mathcal{A}\psi_{j,k}, \psi_{j',k'})_{L^2(\Gamma)}| < \varepsilon_{j,j'}$

where $\varepsilon_{j,j'} \sim \min \left\{ 2^{-|j-j'|}, 2^{-(2J-j-j')\frac{\delta-t}{d+t}} \right\} 2^{-2J(d-t)+(j+j')d'}$.

Modified scheme of Cohen, Dahmen, de Vore:

- Choose : $\mathbf{u}^0 = \mathbf{u}_0^0$
- **For** $k = 1, \dots, K$ **do**
 $\mathbf{u}_{k+1}^{n+1} = \mathbf{u}_k^n - \omega \mathbf{C}^{-1} \mathbf{A}(\mathbf{u}_k^n - \mathbf{f}^n)$
- **Fast Operator Multiplication:** perform $\mathbf{C}^{-1} \mathbf{A} \mathbf{u}_k^n$ by above scheme
- **Error Control:** proceed until $\epsilon_{n+1} \leq 0.5\epsilon_n$
- **Coarsening:** approximate u_K^n by its best N-tree approximation u^n :
 $\|u^n - u_K^n\| \leq \epsilon_n (\sim N_n^{-s})$
- Continue up to desired accuracy

Result: Let $\epsilon_n \sim N^{-s}$, then the complexity to compute a solution u^n with $\|u^n - u\| \leq \epsilon$ is proportional to $N \sim \epsilon^{-1/s}$.

Numerical Results I nonadaptive

Problem: Dirichlet problem in a crankshaft

Single layer operator

$$(\mathcal{V}g)(\mathbf{x}) := \frac{1}{4\pi} \int_{\Gamma} \frac{1}{\|\mathbf{x} - \mathbf{y}\|} g(\mathbf{y}) d\sigma_{\mathbf{y}}$$

Fredholm's integral equation of the first kind

$$\mathcal{V}g = f \quad \text{on } \Gamma$$

→

$$u = \mathcal{V}g \quad \text{in } \Omega$$

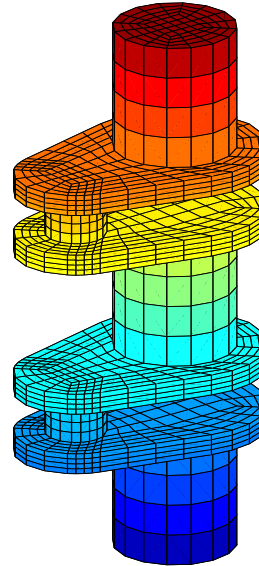

unknowns		piecewise constant wavelets $\psi_{\text{optimized}}^{(1,3)}$				
J	N_J	$\ \mathbf{u} - \mathbf{u}_J\ _\infty$	contr.	cpu-time (in sec.)	a-priori compression (nnz in %)	a-posteriori compression (nnz in %)
1	568	11	—	2	27	20
2	2272	1.0	11	9	8.7	6.7
3	9088	2.5e-1	4.1	76	3.5	1.9
4	36352	2.9e-2	8.4	727	1.1	0.44
5	145408	5.3e-3	5.5	3897 1.1h	0.30	0.10

unknowns		piecewise bilinear wavelets $\psi_{\text{optimized}}^{(2,4)}$				
J	N_J	$\ \mathbf{u} - \mathbf{u}_J\ _\infty$	contr.	cpu-time (in sec.)	a-priori compression (nnz in %)	a-posteriori compression (nnz in %)
1	1278	3.0	—	8	100	99
2	3550	1.3	2.2	36	21	17
3	11502	6.7e-2	19	470	7.8	4.4
4	41038	1.7e-3	41	3975 1.1h	2.7	1.3

Distribution of the cpu-time

- ▶ Dirichlet problem in a crankshaft
- ▶ indirect formulation using the single layer operator
- ▶ performed on a Linux PC with 1 GB RAM

□ Piecewise constant wavelets ($N_J = 145408$)

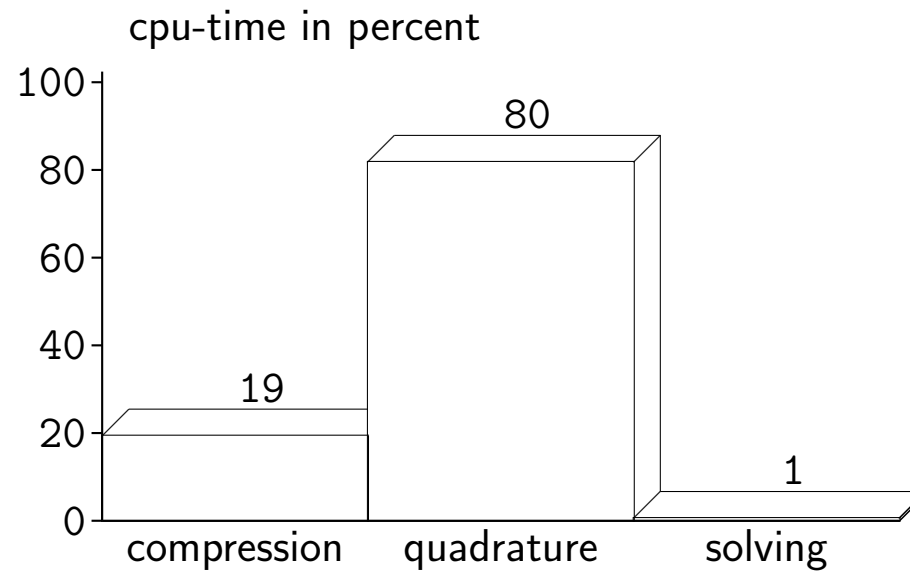

Numerical Results VI

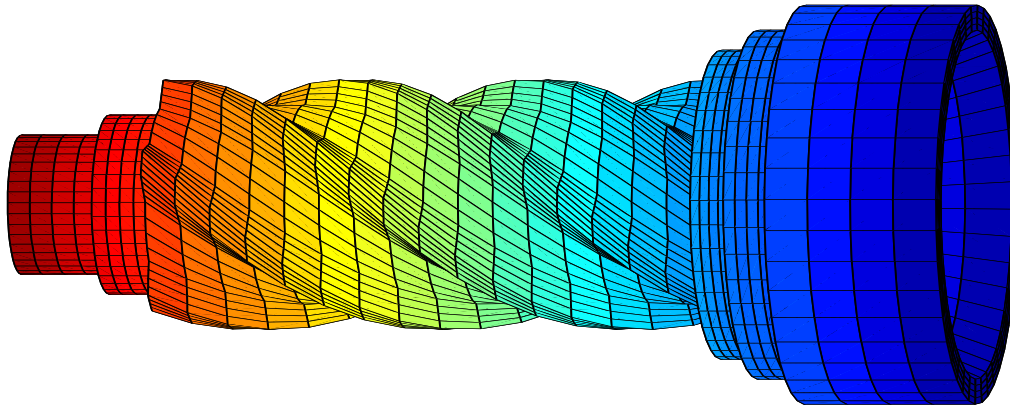

Problem: Dirichlet problem in a gear wheel

Seek $u \in C^2(\Omega) \cap C(\bar{\Omega})$ such that

$$\begin{aligned}\Delta u &= 0 & \text{in } \Omega \subset \mathbb{R}^3 \\ u &= f & \text{on } \Gamma := \partial\Omega, f \in C^1(\Gamma)\end{aligned}$$

Single layer operator

$$(\mathcal{V}g)(\mathbf{x}) := \frac{1}{4\pi} \int_{\Gamma} \frac{1}{\|\mathbf{x} - \mathbf{y}\|} g(\mathbf{y}) d\sigma_{\mathbf{y}}$$

Fredholm's integral equation of the first kind

$$\boxed{\mathcal{V}g = f \quad \text{on } \Gamma} \quad \longrightarrow \quad \boxed{u = \mathcal{V}g \quad \text{in } \Omega}$$

unknowns		adaptive scheme			nonadaptive scheme	
J	$\dim V_J$	$\dim \widehat{V}_J / \dim V_J$	$\ \mathbf{u} - \widehat{\mathbf{u}}_J\ _\infty$	cpu-time	$\ \mathbf{u} - \mathbf{u}_J\ _\infty$	cpu-time
1	1160	100 %	4.6e-1	9	4.7e-1	8
2	4640	100 %	1.8e-1	258	1.9e-1	41
3	18560	27	3.0e-2	421	3.0e-2	488
4	74240	7.7	1.3e-2	828	4.9e-3	4627
5	296960	3.1	1.4e-3	2332	—	—
6	1187840	1.2	5.3e-4	6902	—	—

Numerical Results VII adaptiv

Dirichlet problem in a crankshaft solved by the indirect formulation using the single layer operator

unknowns		piecewise constant wavelets			
J	$\dim V_J$	$\dim \widehat{V}_J / \dim V_J$	$\ \mathbf{u} - \widehat{\mathbf{u}}_J\ _\infty$		cpu-time
1	568	100 %	11	(11)	2 (2)
2	2272	99 %	1.0	(1.0)	16 (9)
3	9088	26 %	2.8e-1	(2.5e-1)	55 (76)
4	36352	7.2	1.8e-2	(2.9e-2)	138 (727)
5	145408	3.0	5.2e-3	(5.3e-3)	456 (3897)
6	581632	1.4	2.1e-3	(—)	1607 (—)
7	2326528	0.70	1.5e-4	(—)	5630 (—)

unknowns		piecewise bilinear wavelets			
J	$\dim V_J$	$\dim \widehat{V}_J / \dim V_J$	$\ \mathbf{u} - \widehat{\mathbf{u}}_J\ _\infty$		cpu-time
1	1278	100 %	3.0	(3.0)	8 (8)
2	3550	100 %	1.3	(1.3)	38 (36)
3	11502	32	6.3e-2	(6.7e-2)	142 (470)
4	41038	11	3.8e-3	(1.7e-3)	539 (3975)
5	154638	5.1	5.4e-4	(—)	3091 (—)
6	599950	2.8	6.3e-5	(—)	21749 (—)

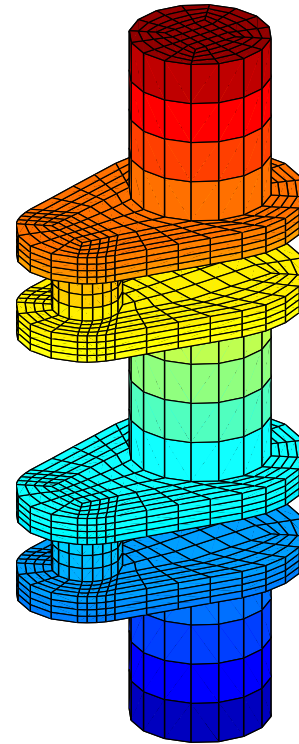

cpu-time vs. accuracy

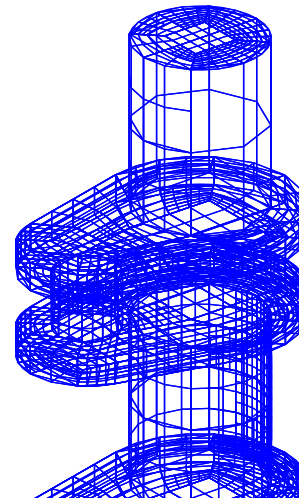
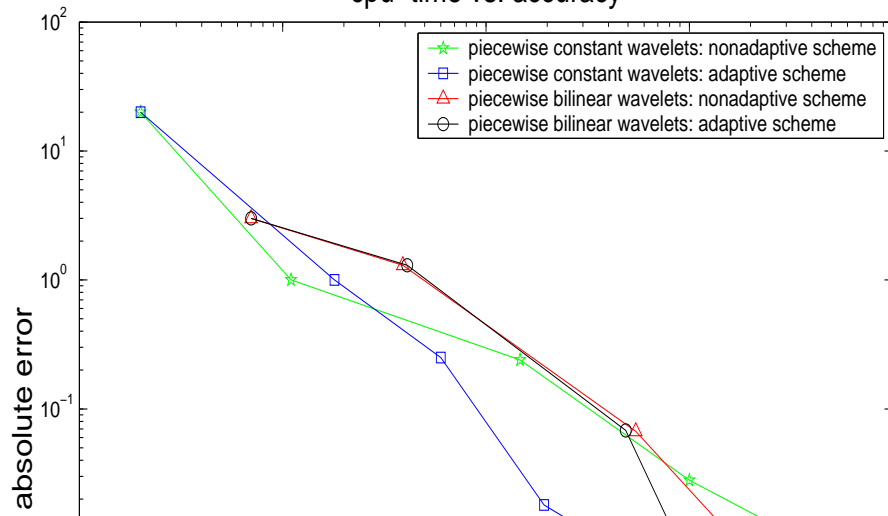

Quadrature

- The quadrature is reduced to element-element interactions
- Tensor product Gauß-Legendre quadrature rules
- Precision of quadrature ($d' > d$)

$$\varepsilon_{j,j'} \sim \min \left\{ 2^{-|j-j'|}, 2^{-(2J-j-j')\frac{2\delta-t}{2d+t}} \right\} 2^{-2J(d'-t)+(j+j')d'}$$

- Direct quadrature of two elements if

$$\text{dist}(\Gamma_{i,j,k}, \Gamma_{i',j',k'}) \geq s > \frac{2^{-\min\{j,j'\}}}{4r}$$

- Quadrature of two elements on the same level:
use the Duffy trick for identical elements and for elements which have a common edge or vertex

□ Adaptive hp -quadrature scheme

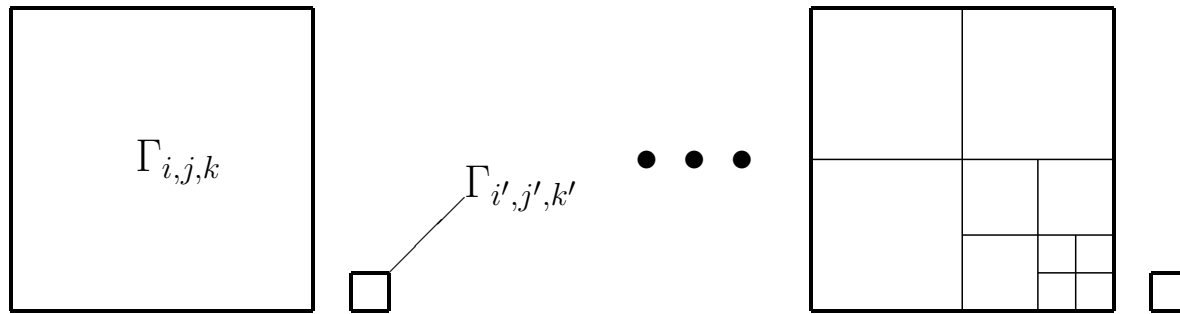

□ Per coefficient $\mathcal{O}\left(\left[J - \frac{j+j'}{2}\right]^4\right)$ function calls

□ The complexity of computing the system matrix is $\mathcal{O}(N_J)$

Adaptivity II

Modification Since setting up matrix coefficients is much more expensive than solving the compressed system. We solve the equation on the next finer layer.

The tree \mathcal{T} corresponds to the space $\widehat{V}_j = \text{span}\{\psi_\lambda : \lambda \in \mathcal{T}(\epsilon_j, \mathbf{u}_j)\}$

Goal: Find a sequence of spaces

$$V_{j_0} = \widehat{V}_{j_0} \subseteq \widehat{V}_{j_0+1} \subseteq \widehat{V}_{j_0+2} \subseteq \cdots \subseteq \widehat{V}_J \subseteq V_J, \quad \widehat{V}_j \subseteq V_j,$$

such that \widehat{u}_j provides the same accuracy as u_j .

Let \widehat{V}_j denote an arbitrary m -graded trial space and $\widehat{V}_{j,\boxplus}$ arises by uniform refinement. We assume that $\widehat{u}_j \in \widehat{V}_j$ and $\widehat{u}_{j,\boxplus} \in \widehat{V}_{j,\boxplus}$

Problem: Find a trial space $\widehat{V}_j \subseteq \widehat{V}_{j+1} \subseteq \widehat{V}_{j,\boxplus}$ such that

$$\|\widehat{u}_{j,\boxplus} - \widehat{u}_{j+1}\|_s \leq \epsilon \|\widehat{u}_{j,\boxplus} - \widehat{u}_j\|_s.$$

Strategy to find $\widehat{V}_j \subseteq \widehat{V}_{j+1} \subseteq \widehat{V}_{j,\boxplus}$:

Numerical Results II

Problem: Dirichlet problem in a gear wheel

Double layer operator

$$(\mathcal{K}g)(\mathbf{x}) := \frac{1}{4\pi} \int_{\Gamma} \frac{\langle \mathbf{x} - \mathbf{y}, \mathbf{n}_y \rangle}{\|\mathbf{x} - \mathbf{y}\|^3} g(\mathbf{y}) d\sigma_y$$

Fredholm's integral equation of the second kind

$$\boxed{(\mathcal{K} - \frac{1}{2})g = f \quad \text{on } \Gamma} \quad \longrightarrow \quad \boxed{u = \mathcal{K}g \quad \text{in } \Omega}$$

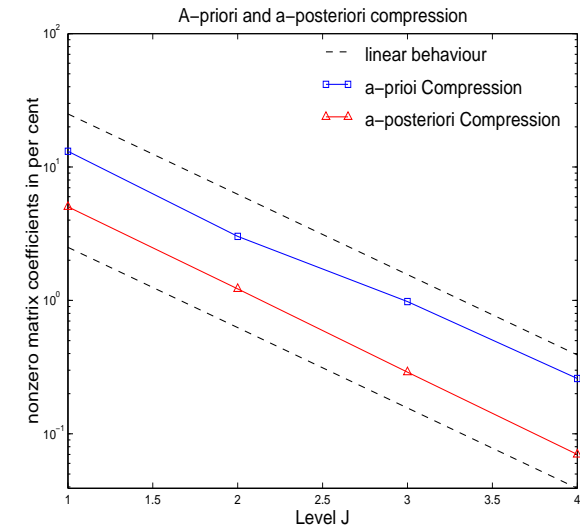
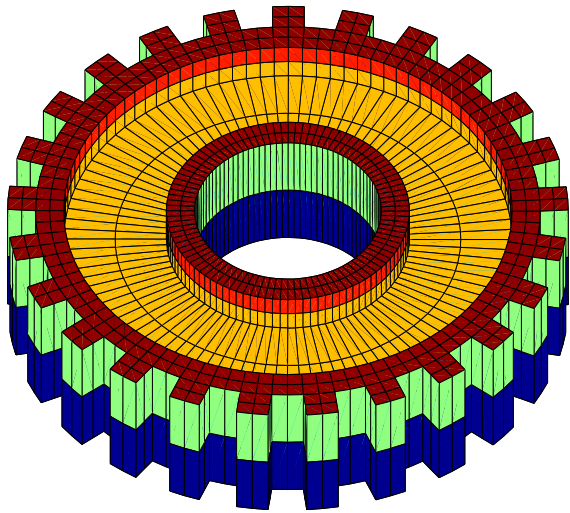

unknowns		wavelets $\psi_{\text{optimized}}^{(1,3)}$			single-scale basis $\phi^{(1)}$
J	N_J	$\ \mathbf{u} - \mathbf{u}_J\ _{\infty}$	contr.	cpu-time (in sec.)	cpu-time (in sec.)
1	2800	1.3	—	10	20
2	11200	1.5e-1	9.8	73	417
3	44800	5.5e-2	2.2	664	6672
4	179200	7.6e-2	4.5	5014 1.4h	106752 30h

□ define an element wise error portion

$$\epsilon_{i,j',k} := 2^{j's} \sqrt{\sum_l [\hat{\mathbf{u}}_{j,\boxplus}(j',l)]^2}.$$

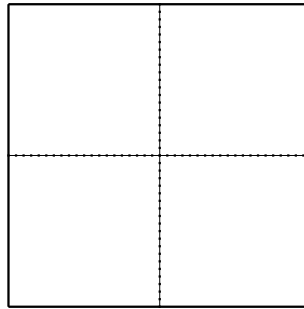

$d = 1$: coefficients of the 3 wavelets corresponding to the subdivision of $\Gamma_{i,j',k}$

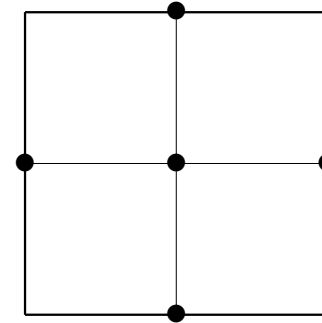

$d = 2$: coefficients of the 5 wavelets corresponding to the new nodes on $\Gamma_{i,j',k}$

□ sort error portions by their modulus and refine \hat{V}_j successively

Algorithm:

initialization: $\widehat{V}_{j_0} := V_{j_0}$
for $j := j_0$ **to** $J - 2$ **do begin**
 compute the system matrix for $\widehat{V}_{j,\boxplus}$
 compute the solutions \widehat{u}_j **and** $\widehat{u}_{j,\boxplus}$
 determine \widehat{V}_{j+1} **with** $\|\widehat{u}_{j,\boxplus} - \widehat{u}_{j+1}\|_s \leq \epsilon \|\widehat{u}_{j,\boxplus} - \widehat{u}_j\|_s$
end
compute the system matrix for $\widehat{V}_{J-1,\boxplus}$
compute the final solution $\widehat{u}_J := \widehat{u}_{J-1,\boxplus}$

Further Results:

- ❑ Coupling FEM& BEM with Harbrecht, Gatica et al.
- ❑ Inverse Problems with Harbrecht and Pereverzev
- ❑ Wavelet Approximation for Nonlinear Operators (PDE's) with Dahmen and Xu
- ❑ Least square methods with Dahmen and Kunoth
- ❑ Preconditioner for p-methods and weighed norms with Beuchler and Schwab
- ❑ Ab initio methods for many particle quantum mechanics with H.J Flad, Hackbusch et al.

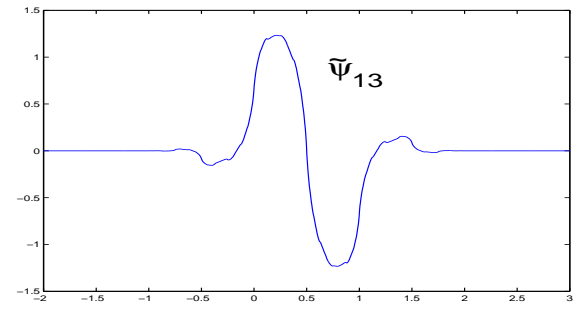
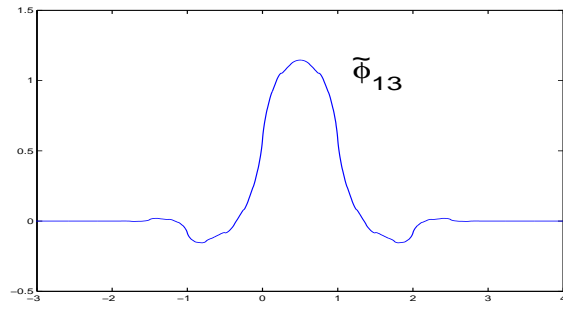
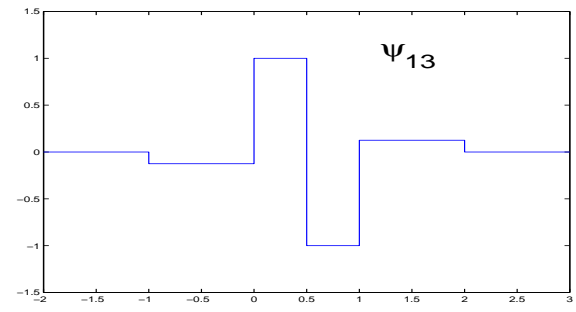
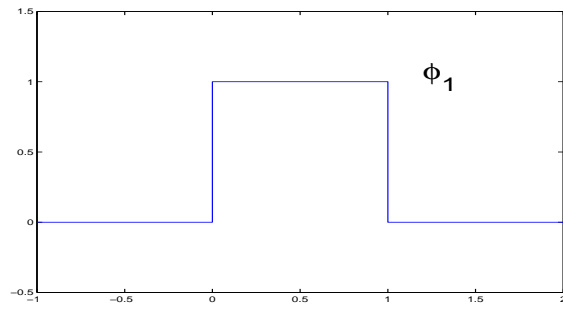

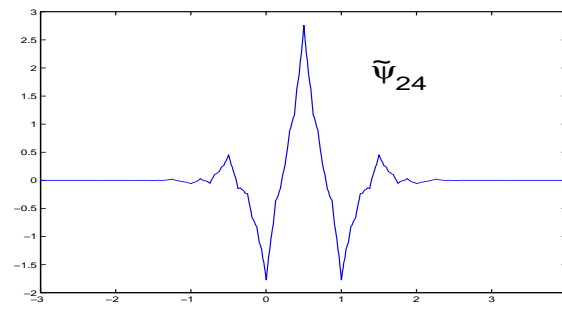
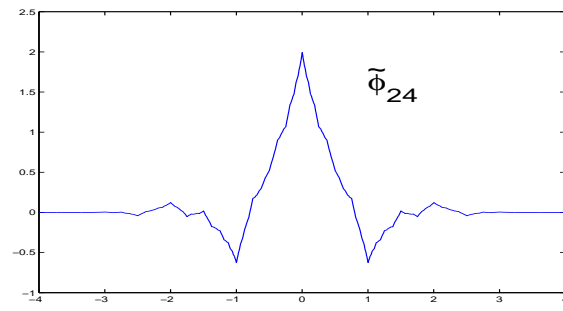
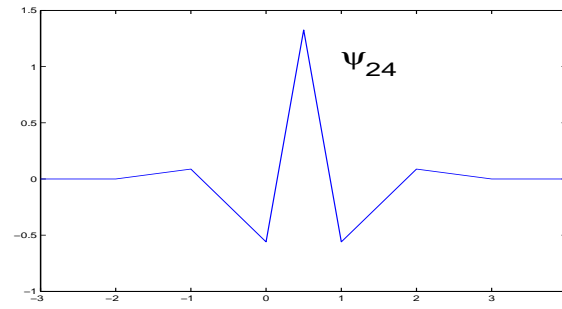
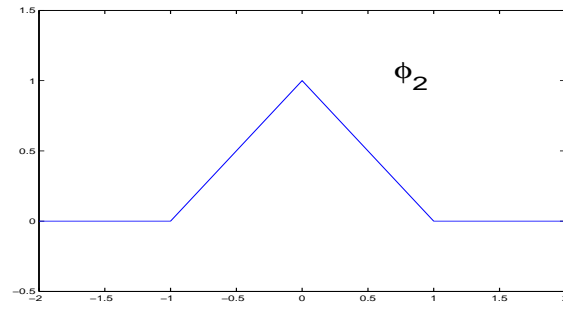

Domain Decomposition

Parametric representation:

$$\square \quad \Gamma = \bigcup_{i=1}^M \Gamma_i, \quad \Gamma_i = \gamma_i(\square), \quad i = 1, \dots, M$$

\square $\Gamma_i \cap \Gamma_{i'}, i \neq i'$, is either empty or a lower dimensional face

$$\square \quad \text{canonical inner product: } (u, v)_{L^2(\Gamma)} = \int_{\Gamma} u(\mathbf{x})v(\mathbf{x})d\sigma_{\mathbf{x}}$$

$$\square \quad \text{modified inner product: } \langle u, v \rangle = \sum_{i=1}^M (u \circ \gamma_i, v \circ \gamma_i)_{L^2(\square)}$$

Parametric surface patch :

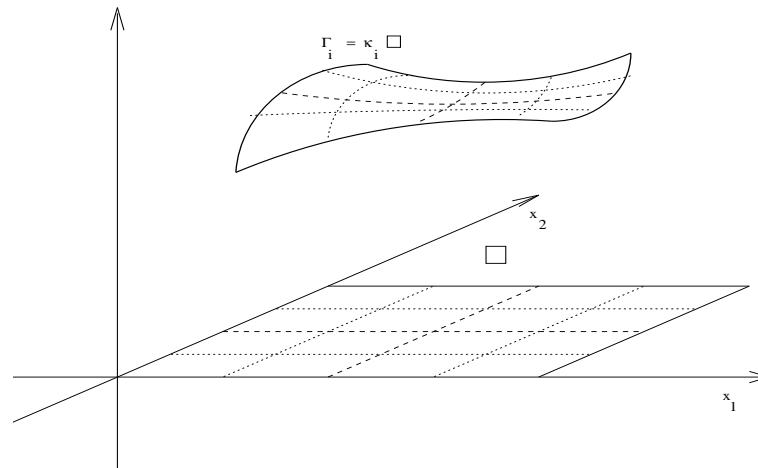

Examples:

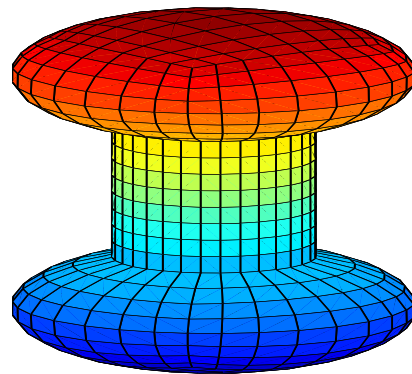
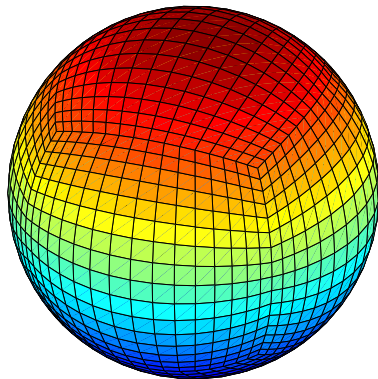

tensor product wavelets $\psi^{(2,2)}$

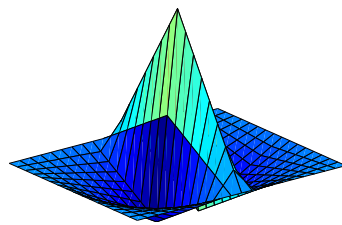

wavelet of type I

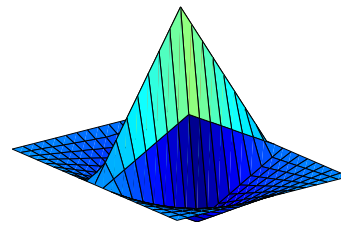

wavelet of type II

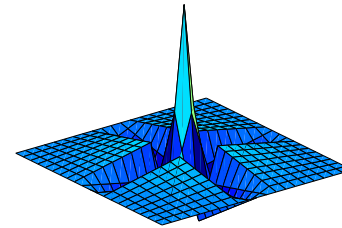

wavelet of type III

simplified tensor product wavelets

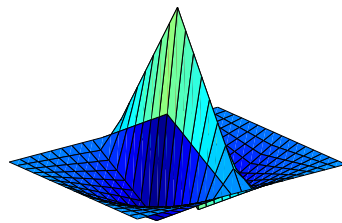

wavelet of type I

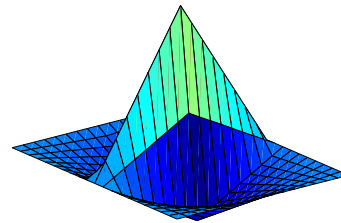

wavelet of type II

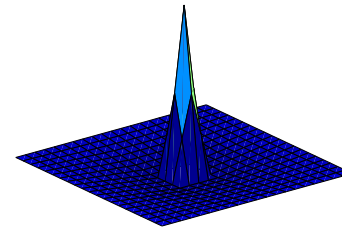

wavelet of type III

wavelets optimized with respect to their support



